



Republic of the Philippines  
**Department of Education**  
 Region IV-A  
 SCHOOLS DIVISION OF QUEZON PROVINCE

  
 DEPED - QUEZON  
 ICT UNIT  
**UPLOADED**  
 Date/Time: **FEB 08 2022**  
 By: **Chisell 2:17 pm**  
 Ref. no. **ITB 003.1.2022**

**Bids and Awards Committee**

**INVITATION TO BID**

PROJECT NO. 2022-02-GOODS

**SUPPLY AND DELIVERY OF SCHOOL FURNITURES (LEARNER'S TABLE & CHAIR SET AND TEACHER'S TABLE & CHAIR SET) FOR SELECTED SCHOOLS IN THE DIVISION OF QUEZON UNDER CY 2022 BEFF SCHOOL FURNITURE PROGRAM**

- The DepED - Division of Quezon, through the Funding Source, Government of the Philippines (GOP) intends to apply the sum of **ONE MILLION NINE HUNDRED SEVENTY NINE THOUSAND FOUR HUNDRED SIXTY PESOS & 00/100 (P1,979,460.00)** being the Approved Budget for the Contract (ABC) to eligible payments under the contract for the **SUPPLY AND DELIVERY OF SCHOOL FURNITURES (LEARNER'S TABLE & CHAIR SET AND TEACHER'S TABLE & CHAIR SET) for SELECTED SCHOOLS IN THE DIVISION OF QUEZON UNDER CY 2022 BEFF SCHOOL FURNITURE PROGRAM**. Bids received that exceed the ABC shall be rejected at bid opening.

PROJECT DESCRIPTION/ INTENDED COMPLETION DATE	ITEM NO.	ITEM DESCRIPTION	APPROVED BUDGET FOR THE CONTRACT (PhP)	AMOUNT OF BIDDING DOCUMENTS	CONTRACT DURATION
SUPPLY AND DELIVERY OF SCHOOL FURNITURES (LEARNER'S TABLE & CHAIR SET AND TEACHER'S TABLE & CHAIR SET) for SELECTED SCHOOLS IN THE DIVISION OF QUEZON UNDER CY 2022 BEFF SCHOOL FURNITURE PROGRAM / 90 CD	1	INDIVIDUAL LEARNER'S TABLE & CHAIR SET- Elem.	P691,582.00	P5,000.00	90 CALENDAR DAYS
	2	INDIVIDUAL LEARNER'S TABLE & CHAIR SET- JHS	P1,244,847.00		
	3	TEACHER'S TABLE & CHAIR SET	P43,031.00		
<b>Grand- Total</b>			<b>P1,979,460.00</b>		

- The DepED-Division of Quezon of Region IV-A, through its Bids and Awards Committee (BAC), now invites bids for the above-mentioned works. Prospective bidders must have an experience of having completed at least one (1) contract that is similar to the contract to be bid, and whose value, adjusted to current prices using the Philippine Statistics Authority (PS) consumer price indices, must be at least fifty percent (50%) of the ABC of

DEPEDQUEZON-TM-SDS-04-025-003



*"Creating Possibilities, Inspiring Innovations"*

Address: Sitio Fori, Brgy. Talipan, Pagbilao, Quezon  
 Trunkline #: (042) 784-0366, (042) 784-0164, (042) 784-0391, (042) 784-0321  
 Email Address: quezon@deped.gov.ph  
 Website: www.depedquezon.com.ph



Republic of the Philippines  
**Department of Education**  
Region IV-A  
SCHOOLS DIVISION OF QUEZON PROVINCE

---

the lot to be bid. The description of an eligible bidder is contained in the Bidding Documents, particularly, in Section II, Instruction to Bidders.

3. Bidding will be conducted through open competitive bidding procedures using a non-discretionary "pass/fail" criterion as specified in the 2016 Revised Implementing Rules and Regulations (IRR) of Republic Act (RA) 9184, otherwise known as the "Government Procurement Reform Act".

Bidding is restricted to Filipino citizens/sole proprietor ships, partnerships, or organizations with at least sixty percent (60%) interest or outstanding capital stock belonging to citizens of the Philippines, and to citizens or organizations of a country the laws or regulations of which grant similar rights or privileges to Filipino citizens, pursuant to RA 5183.

4. Interested bidders may obtain further information from DepED – Division of Quezon and inspect the Bidding Documents at the address given below. A complete set of Bidding Documents may be purchased by interested Bidders and upon payment of a non-refundable fee for the Bidding Documents in the amount stated below. Only bidders who purchased the Bidding Documents will be allowed to submit bids (ITB 6.8).

Bidding Documents may also be downloaded free of charge from the website of the Philippine Government Electronic Procurement System (PhilGEPS), [www.philgeps.gov.ph](http://www.philgeps.gov.ph), provided that bidders shall pay the fee for the Bidding Documents not later than the submission of their bids.

Activity	Date & Time	Venue
Issuance of Bidding Documents	February 7-24, 2022 (9:00 am-4:00 pm)	DepED-Division of Quezon, Talipan, Pagbilao, Quezon
	February 28, 2022 (9:00 am – 12:00 nn)	
Pre-Bid Conference	February 14, 2022 (1:30pm)	online
Final Submission and Opening of Bids	February 28, 2022 (1:30pm)	DepED-Division of Quezon, Talipan, Pagbilao, Quezon





Republic of the Philippines  
**Department of Education**  
Region IV-A  
SCHOOLS DIVISION OF QUEZON PROVINCE

---

5. Considering the current situation due to the pandemic (Covid – 19) and the mandate to observe social distancing, DepED-Quezon will hold a pre-bid conference for the Project on February 14, 2022, 1:30 P.M. through video conferencing, which shall be open to prospective bidders.

Prospective Bidders who intend to participate are required to communicate with the BAC Secretariat through email at [hilariona.coronado@deped.gov.ph](mailto:hilariona.coronado@deped.gov.ph) their confirmation on or before February 14, 2022, 10:00 A.M. Upon receipt of confirmation, the BAC Secretariat will send the link of the meeting.

6. Bids must be delivered to the address and on the date and time stated herein. All Bids must be accompanied by a bid security in any of the acceptable forms and in the amount stated in ITB Clause 18. A valid Bid Securing Declaration must accompany the bid(s) in lieu of the bid security remises

Bids will be opened in the presence of the bidders' representatives who choose to attend the opening of bids at the address stated herein. Late bids shall not be accepted.

In adherence to health protocols and to ensure the safety of everybody, all participants to the submission and opening of bids for the above project are required to present a latest negative result of rapid test / swab test / antigen test, before entering the premises of the Department of Education.

Only one (1) representative per bidder will be allowed entry into the venue / conference room.

**For the purpose of constituting a quorum**, both physical and virtual presence of the BAC members shall be considered pursuant to GPPB Resolution No. 09-2020.

7. The DepEd – Division of Quezon of Region IV-A reserves the right to accept or reject any and all bids, declare a failure of bidding, not award the contract(s) at any time prior to contract award in accordance with Sections 35.6 and 41 of the 2016 revised IRR of RA No. 9184, or annul the bidding process without thereby incurring any liability to the affected bidder or bidders.

---

DEPEDQUEZON-TM-SDS-04-025-003



*"Creating Possibilities, Inspiring Innovations"*

Address: Sitio Fori, Brgy. Talipan, Pagbilao, Quezon

Trunkline #: (042) 784-0366, (042) 784-0164, (042) 784-0391, (042) 784-0321

Email Address: [quezon@deped.gov.ph](mailto:quezon@deped.gov.ph)

Website: [www.depedquezon.com.ph](http://www.depedquezon.com.ph)



Republic of the Philippines  
**Department of Education**  
Region IV-A  
SCHOOLS DIVISION OF QUEZON PROVINCE

---

8. For further information, please refer to:

**Gregorio A. Co, Jr.**  
**BAC Chairman**  
**DepEd – Division of Quezon**  
**Talipan, Pagbilao, Quezon**  
**Contact No. 042-784-0366**

9. You may visit the following websites:

For downloading of Bidding Documents:

- PhilGEPS: <https://notices.philgeps.gov.ph/>
- DepEd-Quezon website: [www.depedquezon.com.ph](http://www.depedquezon.com.ph)

**GREGORIO A. CO, JR.**  
OIC – Asst. Schools Division  
Superintendent  
BAC Chairperson

**TECHNICAL  
SPECIFICATIONS**

**TEACHER'S TABLE**

TECHNICAL SPECIFICATIONS OF TEACHER'S TABLE

MARK	COMPONENTS	SPECIFICATIONS
1		
A	TABLE TOP	18MM THK TOP BOARD ROUND CORNERS (1 SIDE 1.0MM THK HIGH PRESSURE LAMINATE /1 SIDE VARNISH FINISHES ON MARINE PLYWOOD)
B	EDGING	2.0MM THICK PVC EDGING
C	SIDE COVER	0.6MM THICK COLD ROLL STEEL IN POWDER COATED FINISHES
D	FRONT COVER	0.6MM THICK COLD ROLL STEEL IN POWDER COATED FINISHES WITH PUNCH HOLE DESIGN
E	PULL OUT DRAWER	DRAWER FACE : 1 SIDE 1.0MM THK HIGH PRESSURE LAMINATE / 1 SIDE VARNISH FINISHES ON 18MM THICK MARINE PLYWOOD DRAWER BOX : 0.6MM THICK COLD ROLL STEEL IN POWDER COATED FINISHES DRAWER LOCK : 1 LOCK ONLY PER TABLE.
F	MAIN FRAME	400MM LONG RAIL GUIDE 1.0MM THK X 30MM X 30MM STEEL TUBULAR
G	ADJUSTABLE LEVELER	1.0MM THK X 30MM X 30MM STEEL TUBULAR
	CONNECTOR	BMMØ THREAD WITH 38MMØ PLASTIC BASE
	CONNECTION	METAL FRAME BAR AND SCREW
		WOOD TO STEEL: SCREW: WOOD SCREW STEEL TO STEEL: FULL WELDING FOR TUBULAR TO FLAT BAR/CONNECTION STEEL TO STEEL (KNOCKDOWN): BOLT AND NUT FOR STEEL TUBULAR KD. DESIGN IS FOR BIDDER TO PROPOSE

SCHEDULE OF FINISHES

MARK	COMPONENTS	DIMENSIONS	REMARKS
2a	TOP BOARD	18MM THK TOP BOARD ROUND CORNERS (1 SIDE 1.0MM THK HIGH PRESSURE LAMINATE /1 SIDE VARNISH FINISHES ON MARINE PLYWOOD)	
	EDGING	2.0MM THICK PVC EDGING	
	SIDE/FRONT COVER	60-80 MICRON POWDER COAT FINISH FLAT BLACK FINISH	
	METAL/STEEL TUBULAR	60-80 MICRON POWDER COAT FINISH FLAT BLACK FINISH	
	LAMINATE COLOR	PANTONE 729C OR COLOR HEX #8a7c45 / RGB 186, 124, 69 / CMYK 0%, 33%, 63%, 27% WITH WOOD GRAIN (SERRANO BEECH OR EQUIVALENT)	
2b	EDGING - APPLICATION		
1	GLUE APPLICATION ON EDGE OF TABLE TOP		
2	APPLY PVC EDGING AND TRIM AND CLEAN		
3	DIMENSIONS OF TEACHER'S TABLE (mm)		
a	TABLE HEIGHT	750	
b	TABLE LENGTH	1200	
c	TABLE WIDTH	600	
d	SIDING/FRONT COVER	380	

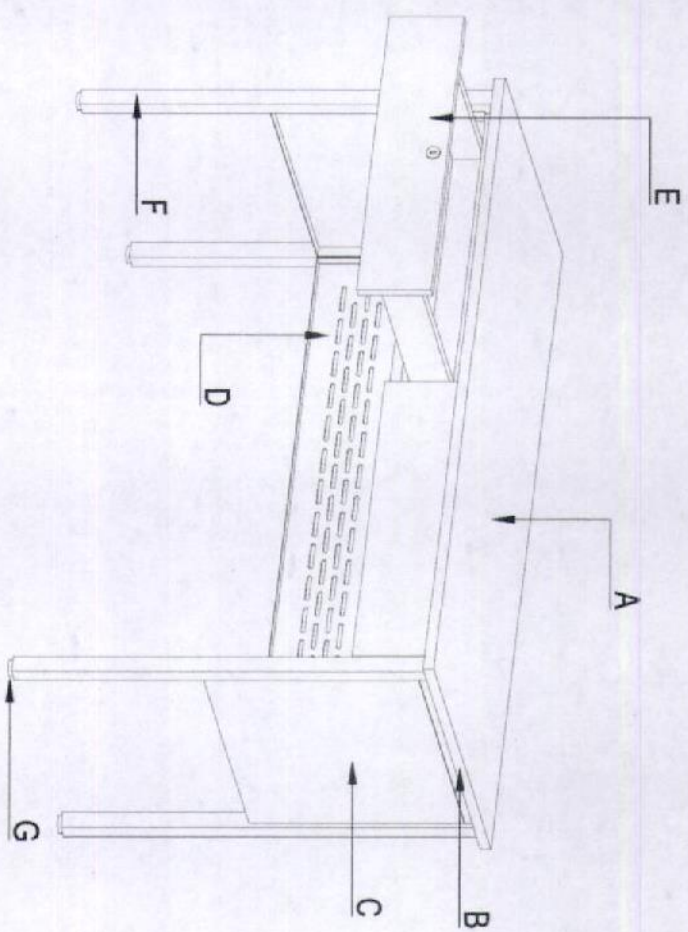

ISOMETRIC VIEW OF TEACHER'S TABLE  
SCALE 1:1

ALL DIMENSION SHALL BE SUBJECTED TO A MAXIMUM TOLERANCE OF PLUS 10MM

DEPED  
DIVISION OFFICE  
MARIKINA CITY

DESIGNED BY :  
*[Signature]*  
LET RAYMOND G. ALABO  
ARCHITECT

RECOMMENDING APPROVAL :  
*[Signature]*  
ENGR. ANIBALDE R. PANGAN  
CHIEF - EDUCATION FACILITIES DIVISION

APPROVED BY :  
ALVIN DEL B. PASQUA  
UNDERSECRETARY FOR ADMINISTRATION

TEACHER'S TABLE  
(WOOD & STEEL)

TECHNICAL SPECIFICATION  
SCHEDULE OF FINISHES  
DIMENSIONS  
ISOMETRIC VIEW

CP 2021

SHEET NO. 1

SHEET NO. 6



REMARKS BY :

RECOMMENDING APPROVAL :

APPROVED BY :

PROJECT TITLE :

SHEET COMMENTS

SHEET NO.

JEY RIVERINO G. ALABISO  
 ARCHITECT

ENGR. ANNABELLE R. PANJAN  
 CHIEF - EDUCATION FACILITIES DIVISION

ALVIN DEL. SI. PASOJA  
 SUPERVISOR FOR ADMINISTRATION

TEACHERS TABLE  
 (WOOD & STEEL)

CV 2021

PLAN  
 PERSPECTIVE  
 FRONT ELEVATION  
 SECTION

2  
 6

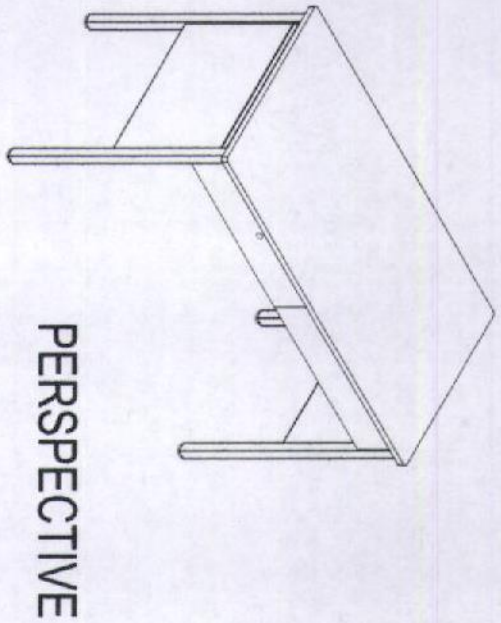
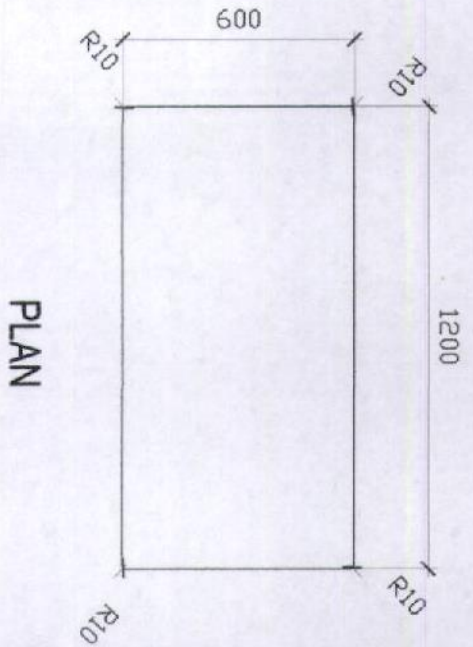
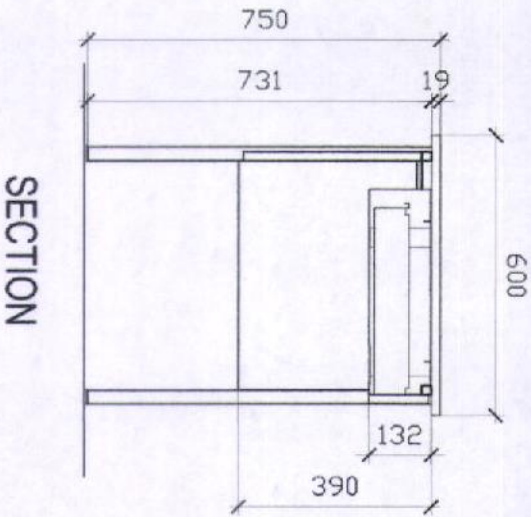
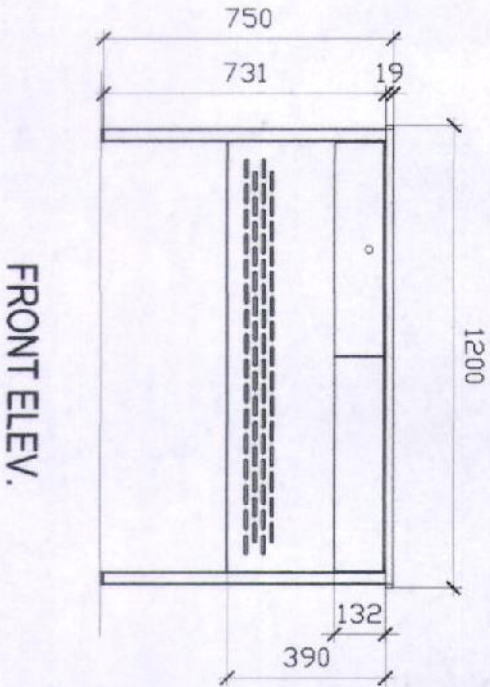

# TEACHER'S TABLE

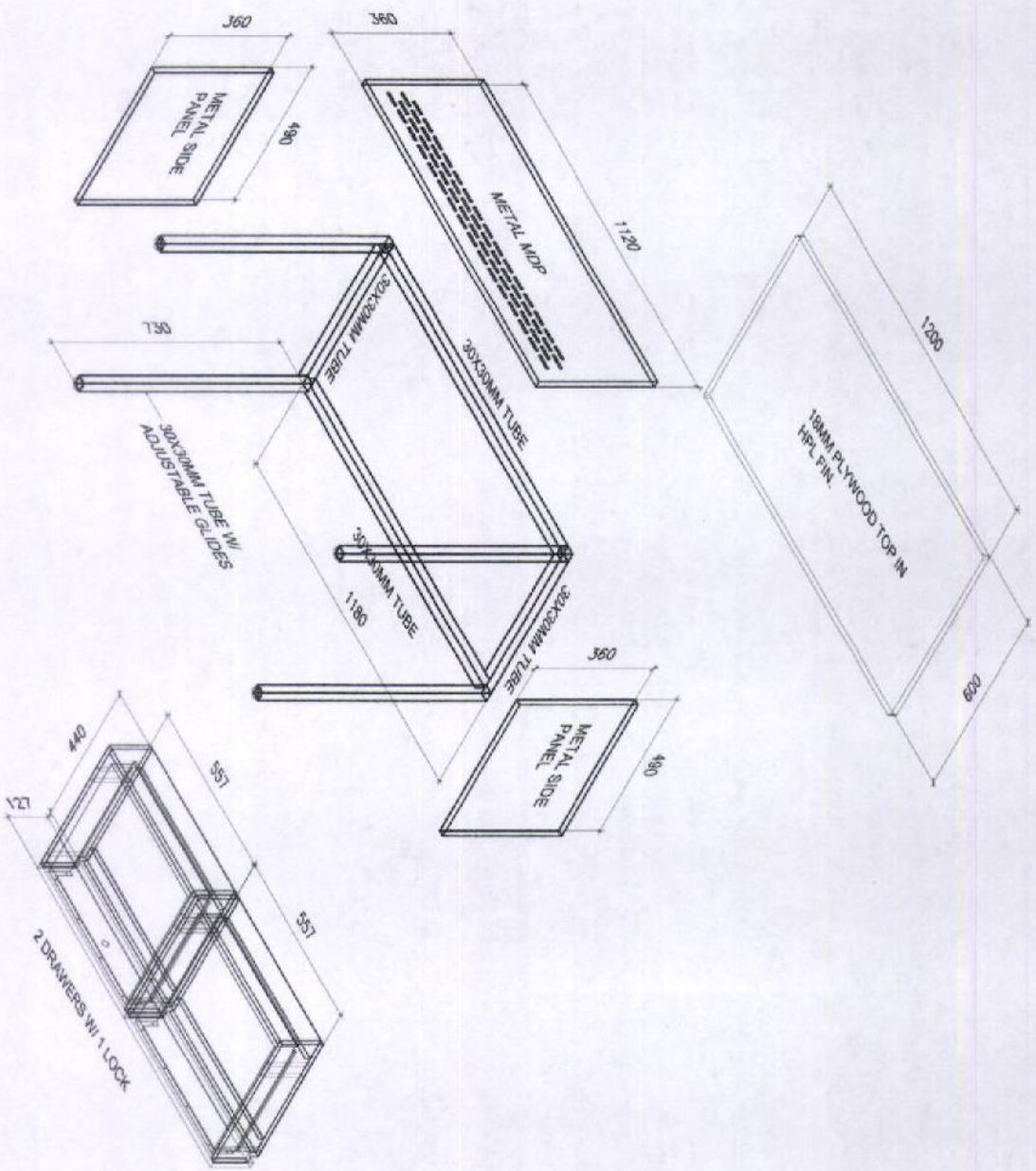

## EXPLODED VIEW

 <p><b>DepEd</b> DIVISION OFFICE - MARIKINA CITY EDUCATION HUMAN RESOURCE MANAGEMENT DIVISION</p>	<p>REVISION BY :</p> <p>LET ROYANNO D. ALABRISO ARCHITECT</p>	<p>RECOMMENDING APPROVAL :</p> <p>ENGR. ANNABELLE R. PANGCIMA CER - EDUCATION HUMAN RESOURCE DIVISION</p>	<p>APPROVED BY :</p> <p>ALAN DEL B. PASQUA SUPERVISOR FOR ADMINISTRATION</p>	<p>PROJECT TITLE :</p> <p>TEACHER'S TABLE (WOOD &amp; STEEL)</p>	<p>SHEET COMMENTS</p> <p>TEACHER'S TABLE EXPLODED VIEW</p>	<p>SHEET NO.</p> <p>3 6</p>
	<p>DATE: 07/2021</p>					

# METAL FRAMING DETAIL

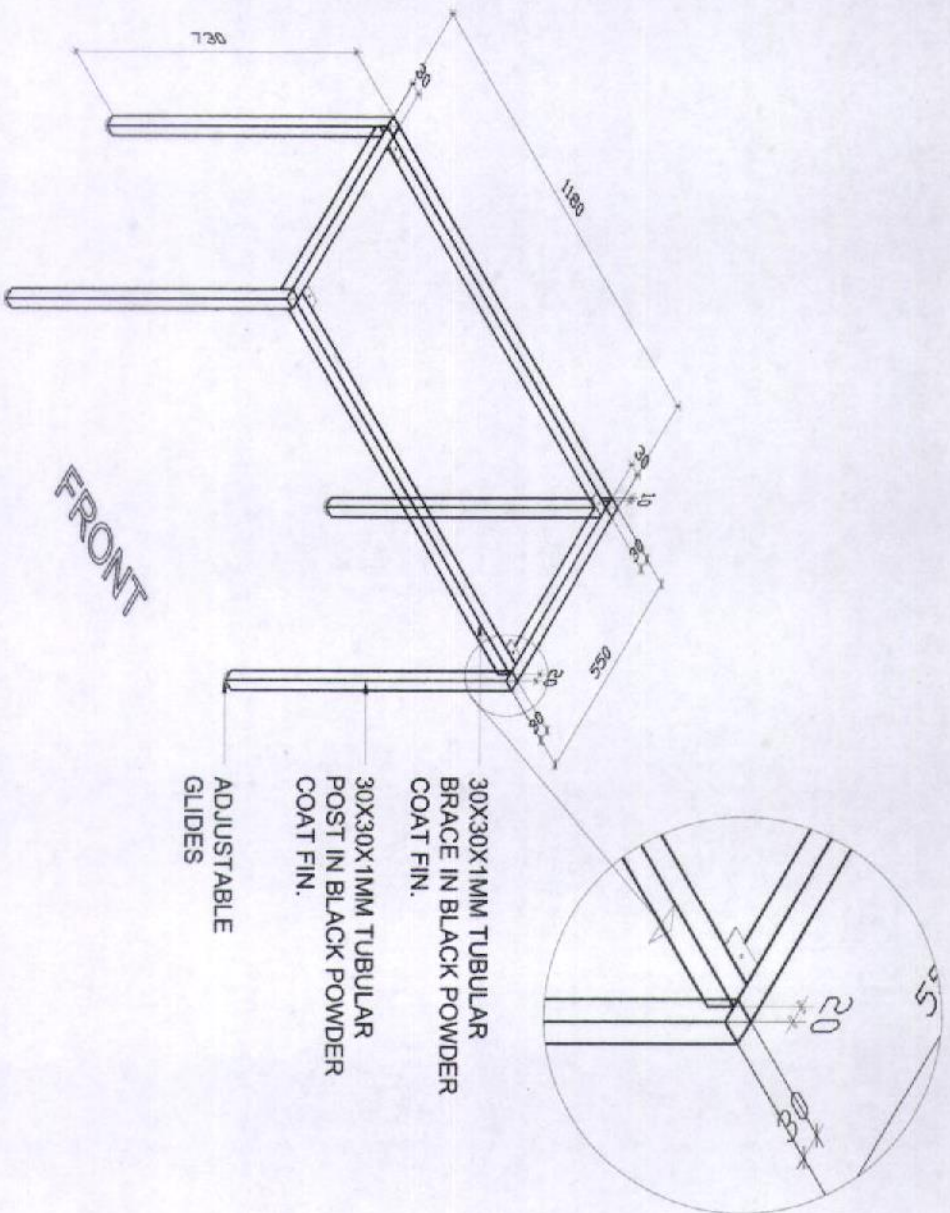

PERSPECTIVE

 <p>DEPARTMENT OF EDUCATION ALASKA 1400 WASHINGTON AVENUE, ANCHORAGE, ALASKA 99501</p>	<p>DESIGNED BY:</p> <p>JET RYLANDER &amp; ASSOCIATES ARCHITECT</p>	<p>RECOMMENDING APPROVAL:</p> <p>ENGR. ANNABELLE S. PANON CHIEF - EDUCATION FACILITIES DIVISION</p>	<p>APPROVED BY:</p> <p>ALAN DEL R. PASQUA UNDERSECRETARY FOR ADMINISTRATION</p>	<p>PROJECT TITLE:</p> <p>TEACHER'S TABLE (WOOD &amp; STEEL)</p>	<p>SHEET CONTENT:</p> <p>METAL FRAMING PERSPECTIVE</p>	<p>SHEET NO.:</p> <p>4 6</p>
---	--	---	---	---	--	----------------------------------

# METAL CENTRAL DRAWER DETAIL

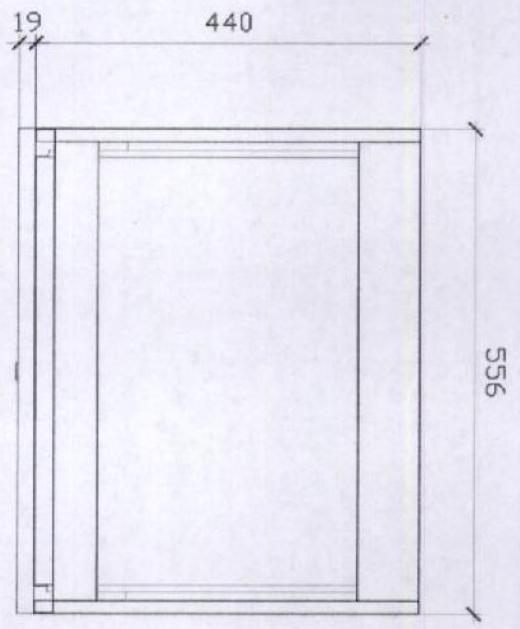

PLAN

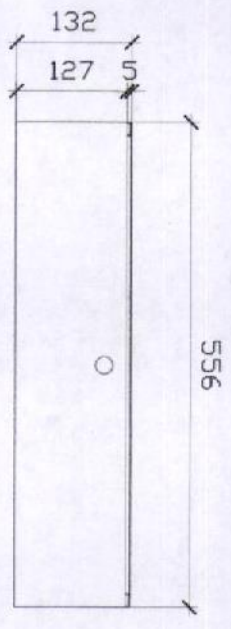

FRONT ELEV.

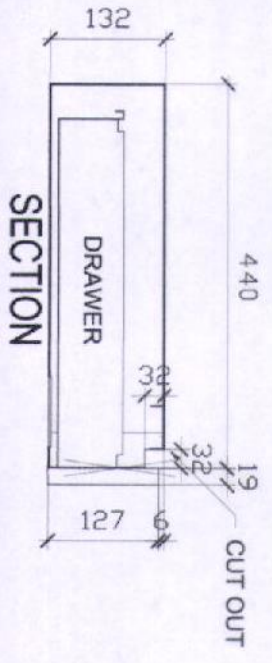

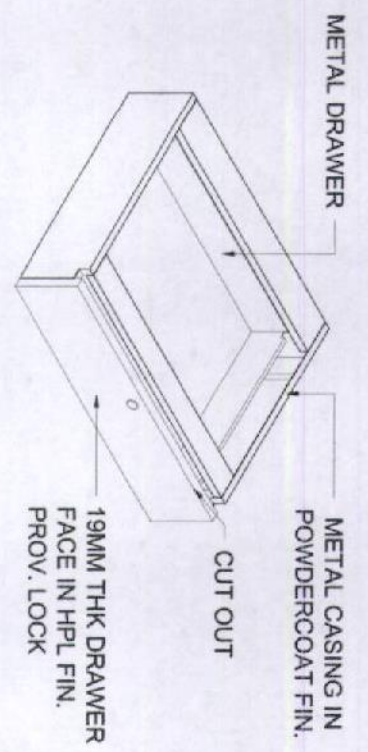

SECTION

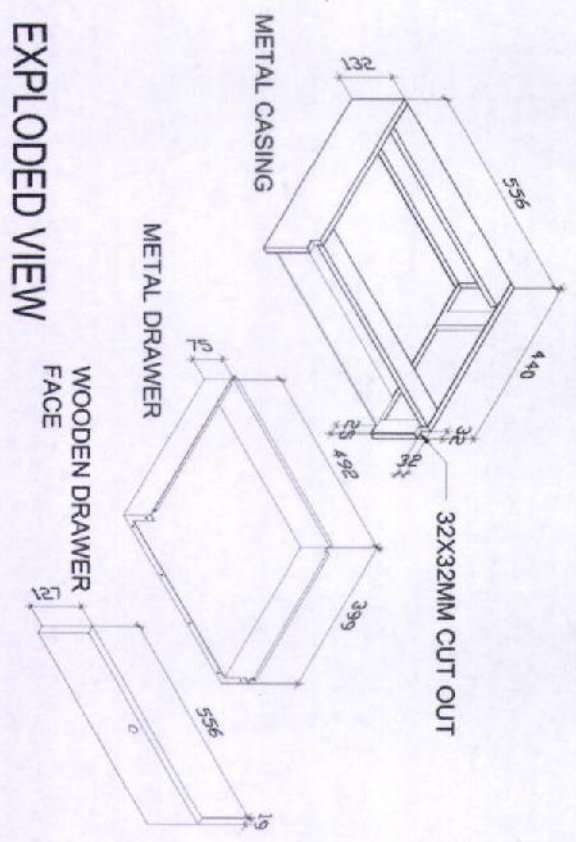

PERSPECTIVE

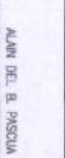

EXPLODED VIEW

 <b>Defied</b> DEPARTMENT OF EDUCATION ELECTRICAL DIVISION 1000 AVONDALE AVENUE, AVONDALE CITY	DRAWING BY :  JET ARCHITECT	RECOMMENDING APPROVAL :  ENGR. ANNEBELLE R. PASCUA CHIEF - EDUCATION FACILITIES DIVISION	APPROVED BY :  ALAN DEL B. PASCUA SUPERVISOR FOR ADMINISTRATION	PROJECT TITLE : <b>TEACHERS TABLE</b> (WOOD & STEEL)	SHEET NUMBER : METAL DRAWER DETAIL FRONT ELEVATION SECTION EXPLODED VIEW PERSPECTIVE	SHEET NO. : <div style="border: 1px solid black; border-radius: 50%; width: 30px; height: 30px; display: flex; align-items: center; justify-content: center;"> <span style="font-size: 24px; font-weight: bold;">5</span> </div> <div style="border: 1px solid black; border-radius: 50%; width: 30px; height: 30px; display: flex; align-items: center; justify-content: center;"> <span style="font-size: 24px; font-weight: bold;">6</span> </div>
	REVISION BY :	PROJECT NO. :	DATE :	SCALE :	DRAWING NO. :	PROJECT NO. :

# PERFORATED MDP & SIDE PANEL DETAIL

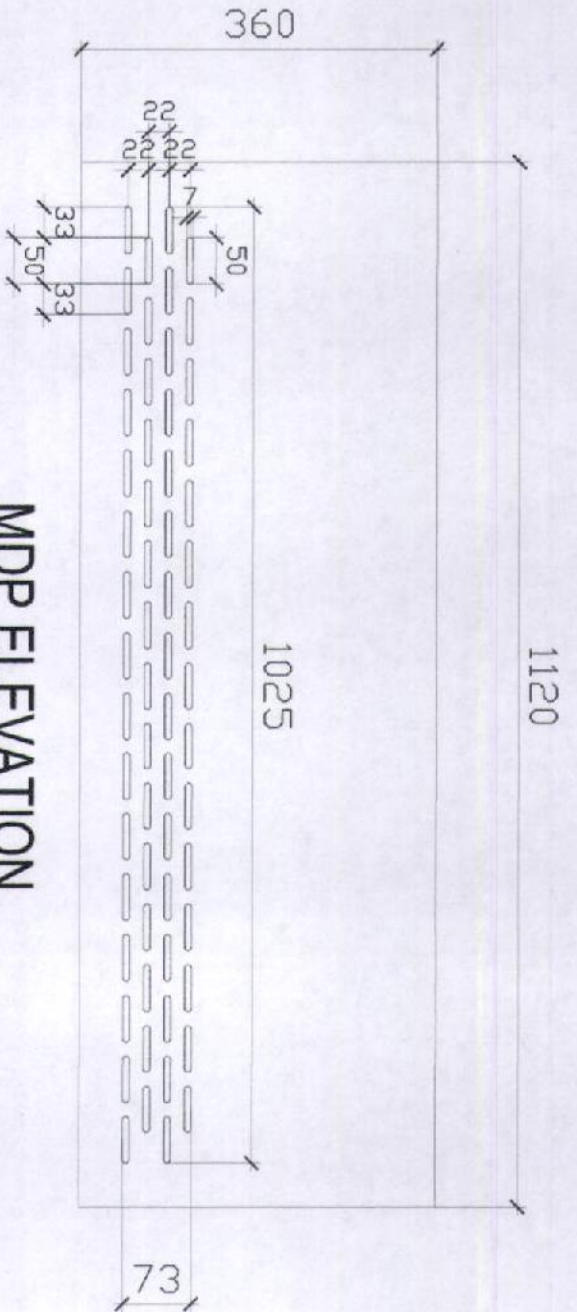

MDP ELEVATION

SIDE PANEL ELEVATION

 <p><b>DepEd</b> DIVISION OFFICE - MARIKINA CITY MARICORAN AVENUE, MARIKINA CITY</p>	<p>DESIGNED BY : <i>JIT BARRERA</i> ARCHITECT</p>	<p>RECOMMENDING APPROVAL : <i>Ernie Anabelle R. Pascua</i> CHIEF - EDUCATION ENGINEERS DIVISION</p>	<p>APPROVED BY : ALAN DEL B. PASCUA SUPERVISOR FOR ADMINISTRATION</p>	<p>PROJECT TITLE : TEACHERS TABLE (WOOD &amp; STEEL)</p>	<p>SHEET CONTENTS PERFORATED MDP &amp; SIDE PANEL DETAIL</p>	<p>SHEET NO. 6</p>
---	---	---	---	--	--	------------------------

**TECHNICAL  
SPECIFICATIONS**

**TEACHER'S CHAIR**

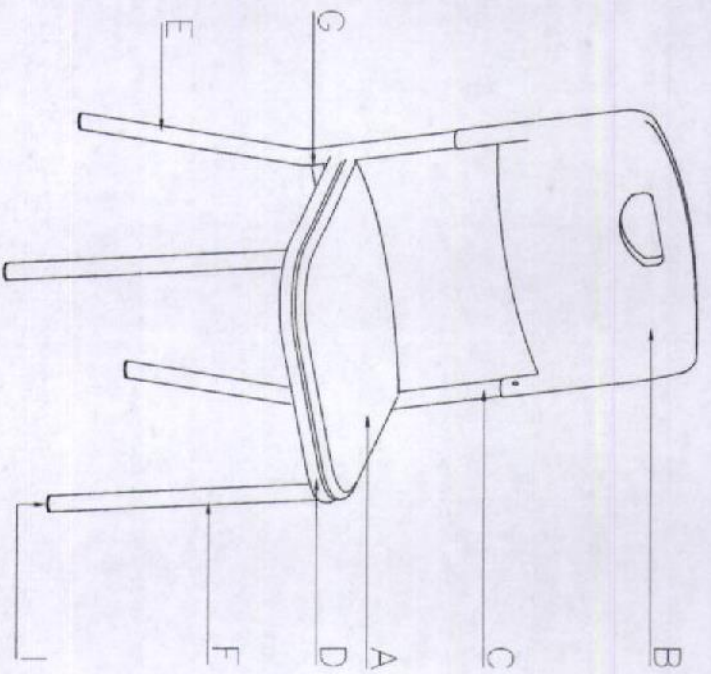

1 ISOMETRIC VIEW OF TEACHER'S CHAIR  
SCALE

DIMENSIONS OF TEACHER'S CHAIR (mm)

COMPONENTS	DIMENSIONS
SEAT HEIGHT	412
SEAT DEPTH	380
SEAT WIDTH	370
BACK HEIGHT	800
BACK WIDTH	410

1 TECHNICAL SPECIFICATIONS OF TEACHER'S CHAIR	
MARK	COMPONENTS
A	SEAT
B	BACK
C	BACK SUPPORT
D	SEAT SUPPORT
E	BACK LEG
F	FRONT LEG
G	LOWER SEAT SUPPORT
I	COVER CAP
	HDPE TO STEEL
	SEAT HDPE TO STEEL - 1MM THK 25MMX30MM FLAT BAR, M6X12 BOLT

SPECIFICATIONS

SCHEDULE OF FINISHES

BLOW MOLDED	HIGH-DENSITY POLYETHYLENE (HDPE) PLASTIC
METAL/STEEL TUBULAR	60-80 MICRON POWDER COAT FINISH FLAT BLACK FINISH
HDPE COLOR	REFER TO COLOR CODE PANTONE 4665C OR COLOR HEX: #cdd788 / RGB: 205, 167, 136 / CMYK: 0%, 19%, 34%, 20%

**DepEd**  
DIVISION OFFICE - MARIKINA CITY

DESIGNED BY: *JE PARRASO*  
REVISOR: *[Signature]*

RECOMMENDED APPROVAL: *[Signature]*  
ENGR. ANIBALLETTA PANCAN  
CHIEF - EDUCATIONAL FACILITIES DIVISION

APPROVED BY: *[Signature]*  
ALAN DEL B. PASCUA  
INSPECTOR GENERAL FOR ADMINISTRATION

PROJECT TITLE: **TEACHER'S CHAIR (HDPE & STEEL)**

DATE: **CV 2021**

TECHNICAL SPECIFICATION  
SCHEDULE OF FINISHES  
DIMENSIONS  
SCALE: TRIC VIEW

1

2

# DEPED TEACHER'S CHAIR

**DEPED LOGO SPECIFICATIONS FOR ALL LEARNER AND TEACHER'S CHAIR**

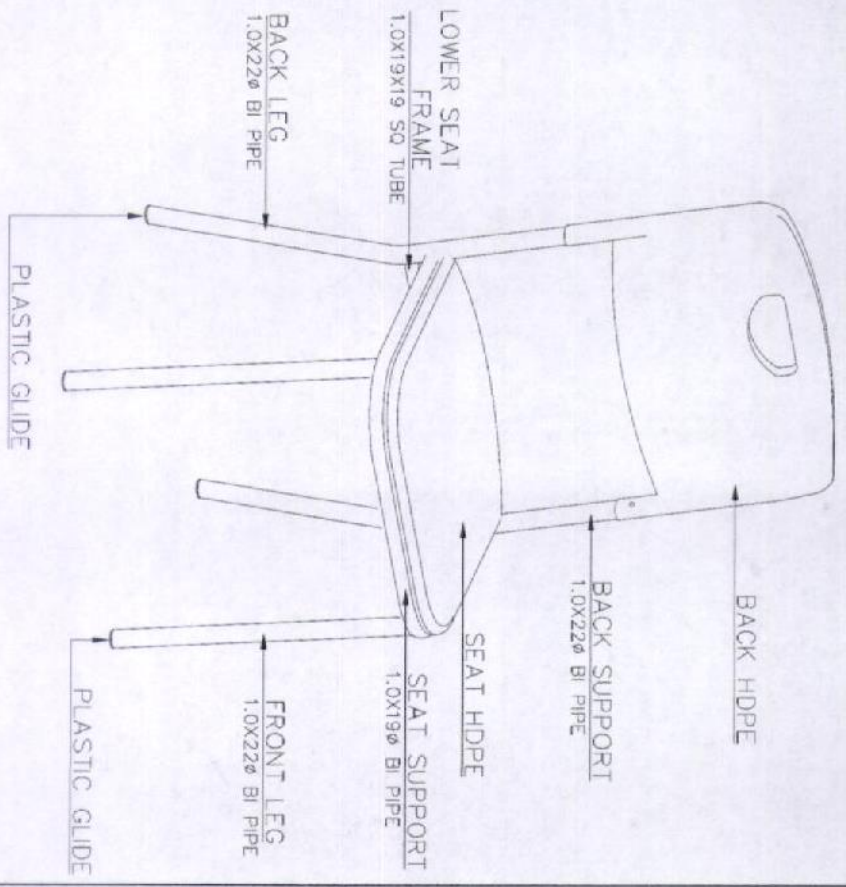
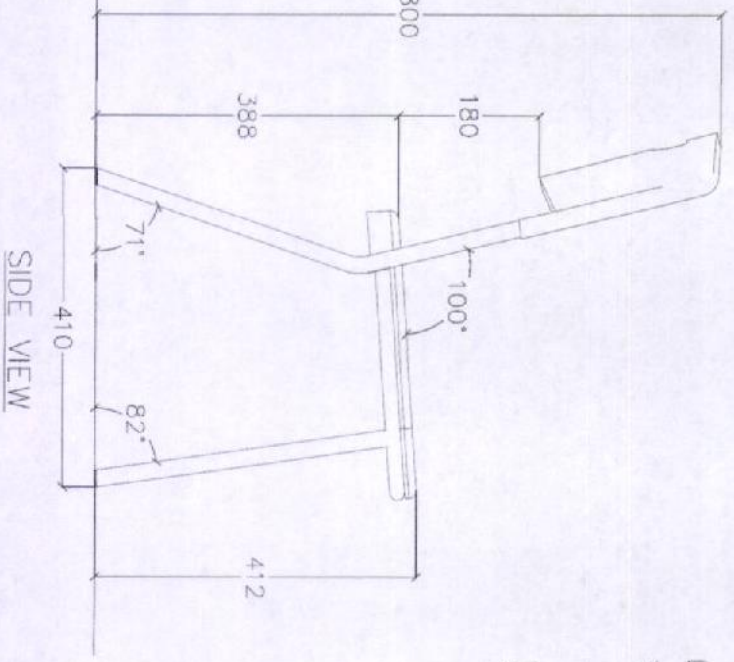
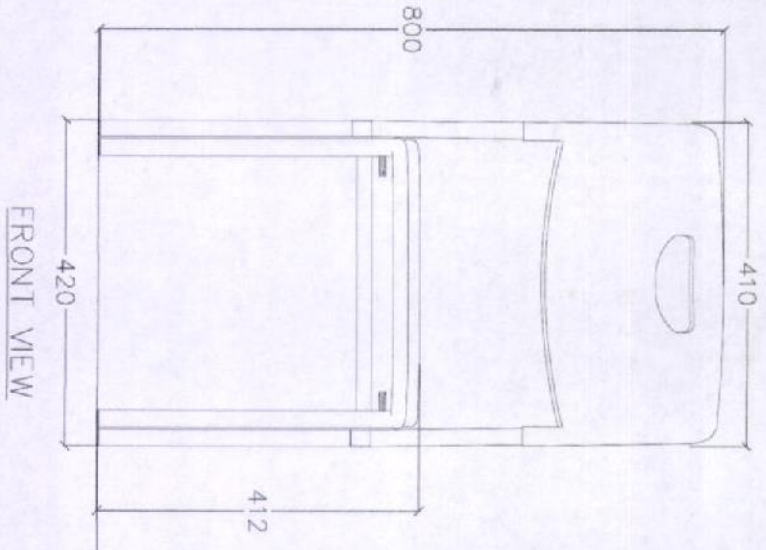
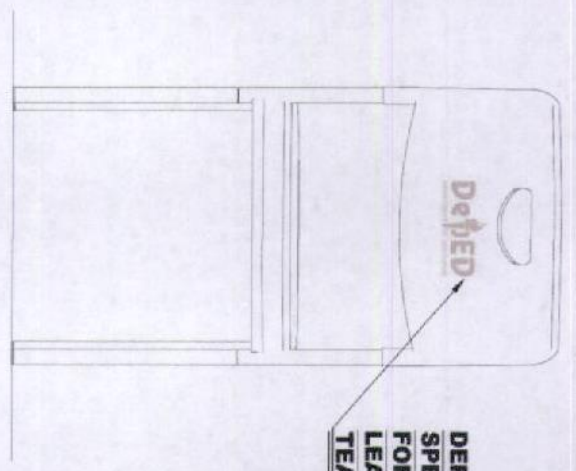
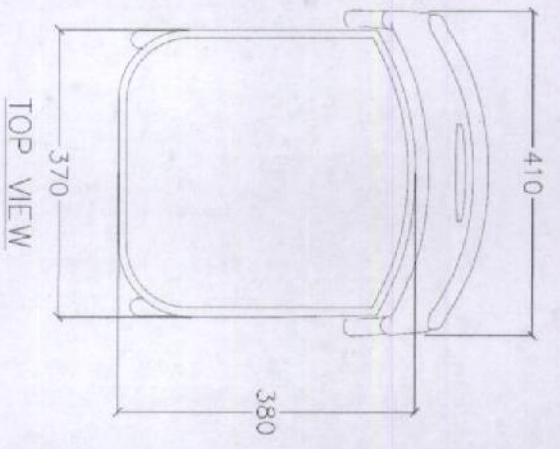

**TEACHER'S CHAIR PERSPECTIVE VIEW**

 <p>DEPED DEPARTMENT OF EDUCATION BUREAU OF TECHNICAL EDUCATION OFFICE OF THE SUPERVISOR SCHOOL DIVISION OFFICE - CALABARZON</p>	<p>DESIGNED BY: JIT BERNARDO &amp; PALMADO ARCHITECT</p>	<p>RECOMMENDED BY: ENGR. ANSELMO P. RAMON CHIEF - EDUCATION FACILITIES DIVISION</p>	<p>APPROVED BY: MANN DEL B. PASOJA SUPERVISOR FOR ARCHITECTURE</p>	<p>PROJECT TITLE: TEACHER'S CHAIR (HDPE &amp; STEEL)</p>	<p>SHEET CONTENTS: PERSPECTIVE TOP, FRONT, SIDE &amp; REAR VIEWS</p>	<p>SHEET NO. 2</p>
	<p>DATE: 01/20/2011</p>					

# DEPED LOGO SPECIFICATIONS FOR ALL LEARNER AND TEACHER'S CHAIR

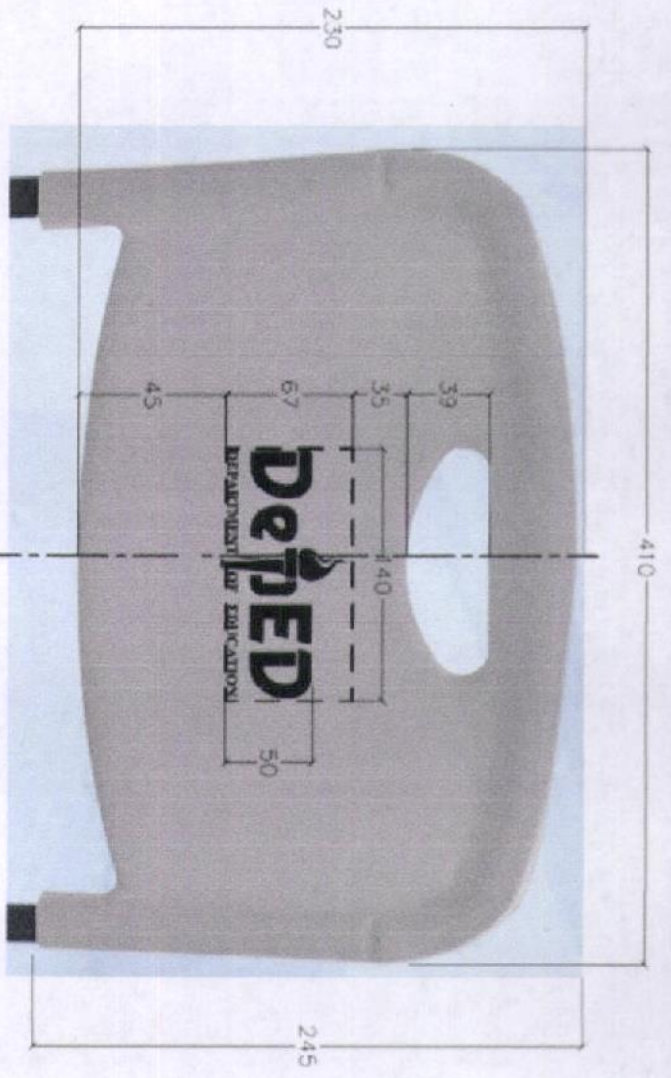

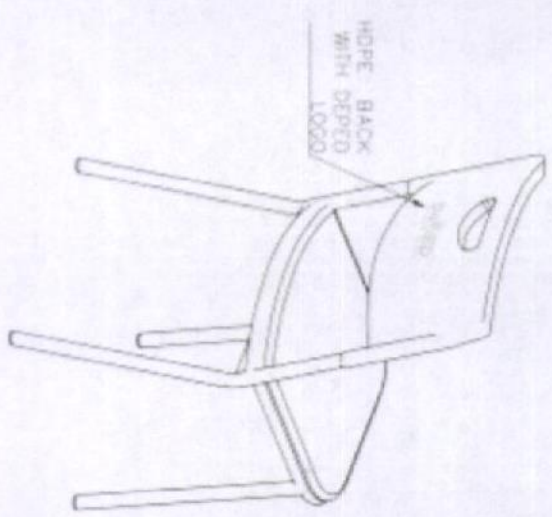

HDPE BACK DEPED LOGO DETAIL



PERSPECTIVE VIEW

SPECIFICATIONS:

1. MATERIAL: BLOW MOLDED HDPE.
  2. MARKINGS: MINIMUM OF 0.8MM DEPTH EMBOSSED / MOLDED OFFICIAL "DepEd LOGO" WITH THE INSCRIPTION "DEPARTMENT OF EDUCATION" AS PER DRAWING.
  3. COLOR CODE: PANTONE 4665C OR COLOR HEX: #cda788 / RGB: 205, 167, 136 / CMYK: 0%, 19%, 34%, 20%
  4. DEPED LOGO COLOR IS THE SAME AS BACKREST COLOR CODE.
- NOTE: BLACK COLOR OF LOGO SHOWN IS FOR ILLUSTRATION ONLY.

 <p>DEPARTMENT OF EDUCATION BUREAU OF ASSISTANT SECRETARIES OFFICE OF THE ASSISTANT SECRETARY FOR LEARNING TECHNOLOGY</p>	<p>DESIGN BY :</p>  <p>J. B. PASCUA ARCHITECT</p>	<p>RECOMMENDING OFFICIAL :</p>  <p>ENGR. ARABELLE PASION CHIEF - DESIGN FACTORY DIVISION</p>	<p>APPROVED BY :</p> <p>ALAN DEL B. PASCUA UNDERSECRETARY FOR MANAGEMENT</p>	<p>PROJECT TITLE :</p> <p>LEARNER &amp; TEACHER'S CHAIR - HDPE BACK DEPED LOGO DETAIL (HDPE &amp; STEEL)</p>	<p>SHEET NUMBER</p> <p>HDPE BACK DEPED LOGO DETAIL PERSPECTIVE VIEW SPECIFICATIONS CY 2021</p>	<p>SHEET NO.</p> <p>1 / 1</p>
---	---	--	--	--	--	-------------------------------

**TECHNICAL  
SPECIFICATIONS**

**LEARNER'S TABLE**

1 TECHNICAL SPECIFICATIONS OF LEARNER'S TABLE

MARK	COMPONENTS	SPECIFICATIONS
A	TABLE TOP	18MM THK TOP BOARD ROUND CORNER'S (1 SIDE 1.0MM THK HIGH PRESSURE LAMINATE/1 SIDE VARNISH FINISHES ON MARINE PLYWOOD)
B	EDGING	1.0 MM THK PVC EDGING, ALL EDGES OF TABLE TOP
C	SHELF	METAL WIRE MESH 4MMTHKX50X50
D	FRONT COVER	6MM THK FRONT COVER (1 SIDE 1.0MM THK HIGH PRESSURE LAMINATE / 1 SIDE VARNISH FINISHES ON MARINE PLYWOOD)
E	MAIN FRAME	1.0MMTHKX20MMX40MM STEEL TUBULAR
F	SECONDARY FRAME	1.0MMTHKX20MMX20MM STEEL TUBULAR
G	ADJUSTABLE LEVELER	ØMMØ THREAD WITH 3ØMMØ PLASTIC BASE
	CONNECTOR/FLAT BAR	1MMTHKX25MMX50MM STEEL FLAT BAR (TABLE TOP: 4PCS;SCREW)
	CONNECTION	WOOD TO STEEL: SOREW: M5X12MM LENGTH SOREW: RIVETS: BLIND RIVET STEEL TO STEEL: FULL WELDING FOR TUBULAR TO FLAT BAR/CONNECTION STEEL TO STEEL (KNOCKDOWN): BOLT AND NUT FOR STEEL TUBULAR KD DESIGN IS FOR BIDDER TO PROPOSE

2a SCHEDULE OF FINISHES

TOP BOARD	1 SIDE 1.0MM THK HIGH PRESSURE LAMINATE / 1 SIDE VARNISH FINISHES ON MARINE PLYWOOD
EDGING	1.0 MM THK PVC EDGING, ALL EDGES OF TABLE TOP
FRONT COVER	1 SIDE 1.0MM THK HIGH PRESSURE LAMINATE /1 SIDE VARNISH FINISHES ON MARINE PLYWOOD)
METAL/STEEL TUBULAR	60-80 MICRON POWDER COAT FINISH FLAT BLACK FINISH
LAMINATE COLOR	PANTONE 729C OR COLOR HEX #b07c45 / RGB 186, 124, 69 / CMYK 0%, 33%, 63%, 27% WITH WOOD GRAIN (SERANO BEECH OR EQUIVALENT)

2b EDGING - APPLICATION

1	MACHINE APPLICATION OF GLUE TO TABLE TOP EDGES
2	MACHINE APPLICATION OF PVC EDGING TO TABLE TOP EDGES

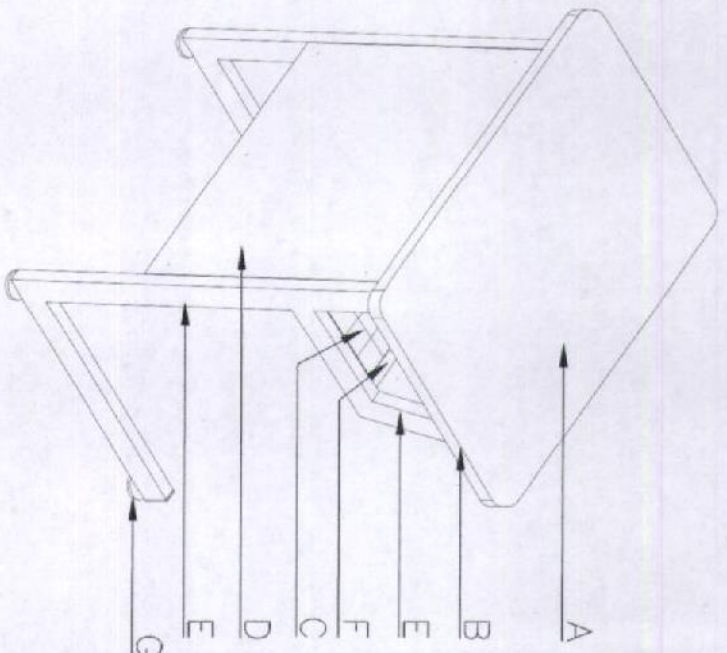

ISOMETRIC VIEW OF LEARNER'S TABLE  
SCALE 1/4"

3 DIMENSIONS OF LEARNER'S TABLE(mm)

MARK	COMPONENTS	DIMENSIONS	
		ELEMENTARY	SECONDARY
d	TABLE HEIGHT	670 (+10)	710 (+10)
b	TABLE LENGTH	600	600
c	TABLE WIDTH	400	400



**DepEd**  
DIVISION OFFICE OF THE CARAGA  
EDUCATIONAL SERVICES CENTER  
DURAN, DAVAO DEL SUR

DESIGNED BY:  JET REYNOLDO G. ALABRADO  
ARCHITECT

RECOMMENDING APPROVAL:  DHR ANABELLE DE PASIGAN  
CHIEF - EDUCATION PLANNING DIVISION

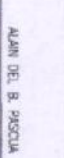
APPROVED BY:  ADM DEL B. PASIGAN  
UNDERSECRETARY FOR ADMINISTRATION

PROJECT TITLE: **LEARNER'S TABLE (WOOD & STEEL)**

TECHNICAL SPECIFICATION  
SCHEDULE OF FINISHES  
EDGING APPLICATION  
ISOMETRIC VIEW

SHEET NO. **1**  
OF **3**

CY 2021



# DEPED SECONDARY SINGLE LEARNER'S TABLE

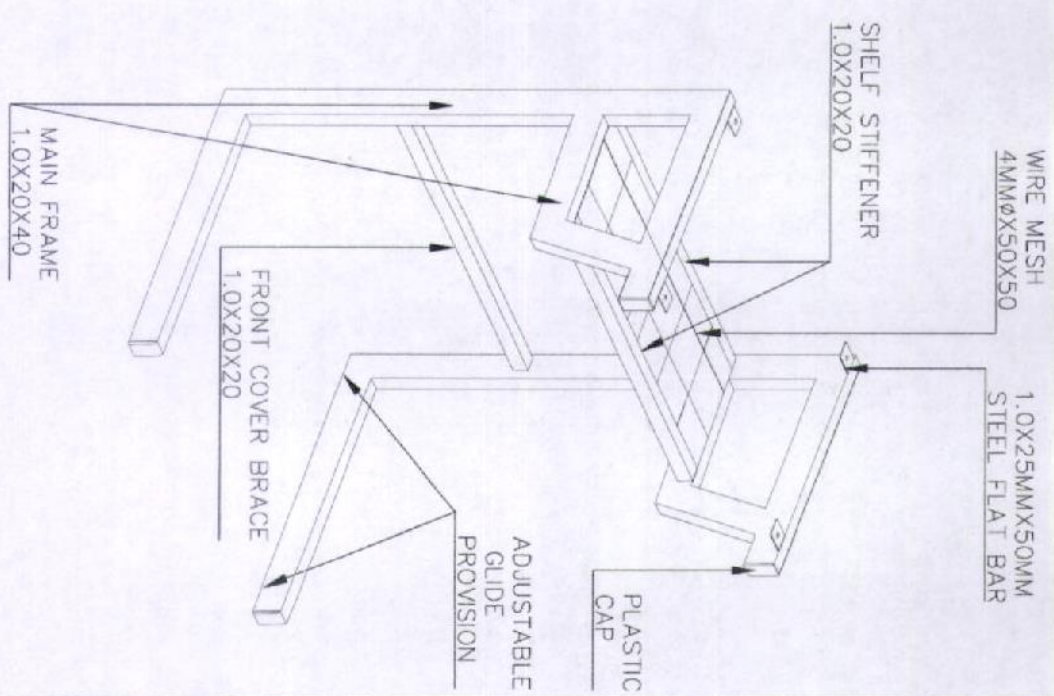
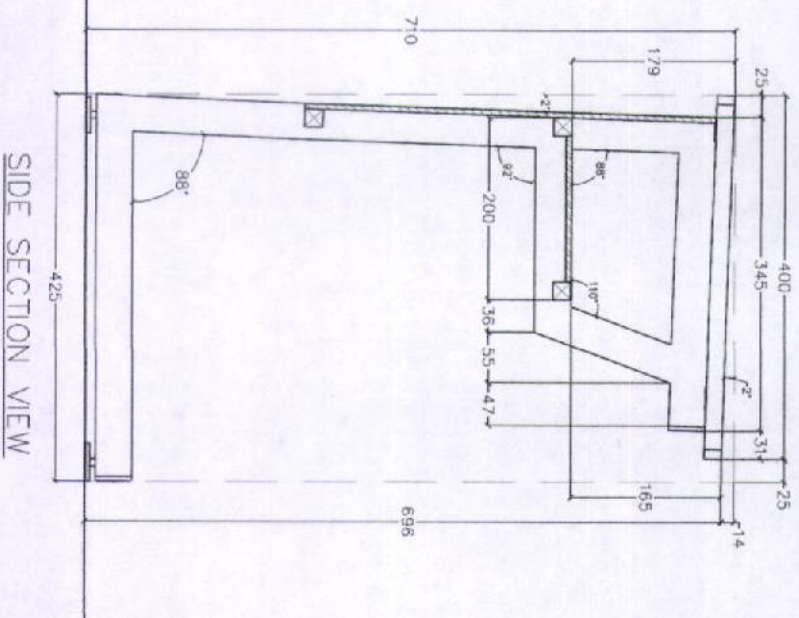
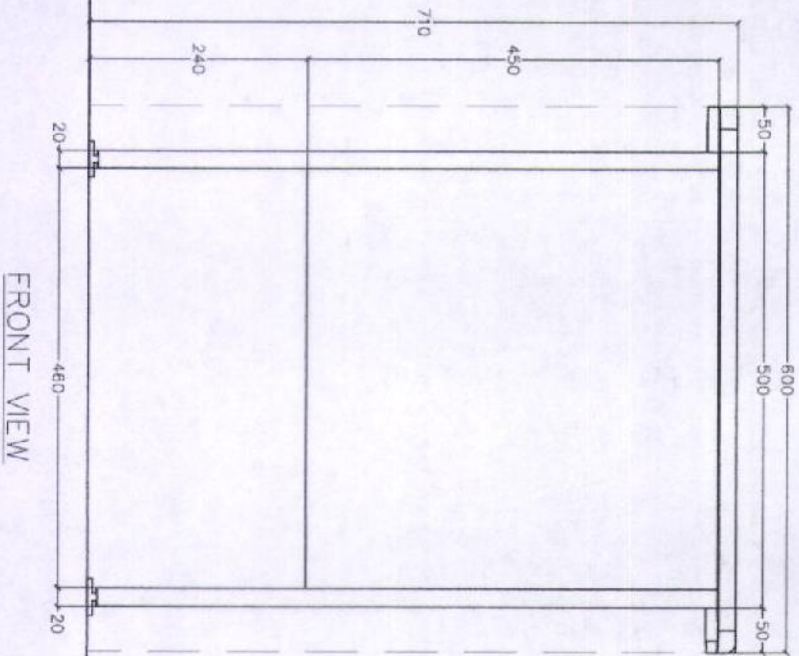
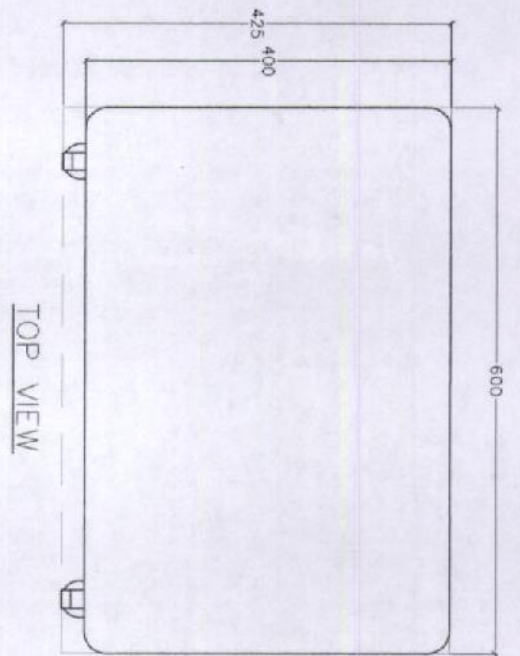

REVISION BY :  
LET ROYALDO C. ALABANO  
ARCHITECT

REWORKING APPROVAL :  
ENGR. ANNABELLE PANGAN  
CHIEF - EDUCATION FACILITY DESIGN

APPROVED BY :  
ALAN DEL B. PASCUA  
SUPERVISOR FOR ADMINISTRATION

PROJECT TITLE :

LEARNER'S TABLE  
(WOOD & STEEL)

CV 2021

SHEET CONTENTS  
TOP VIEW  
FRONT VIEW  
SIDE SECTION VIEW  
FRAMING PERSPECTIVE VIEW

SHEET NO.  
3  
3

**TECHNICAL  
SPECIFICATIONS**

**LEARNER'S CHAIR**

# DEPED LOGO SPECIFICATIONS FOR ALL LEARNER AND TEACHER'S CHAIR

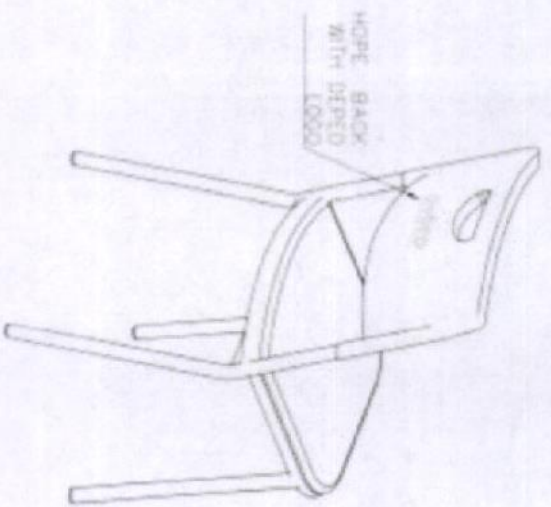
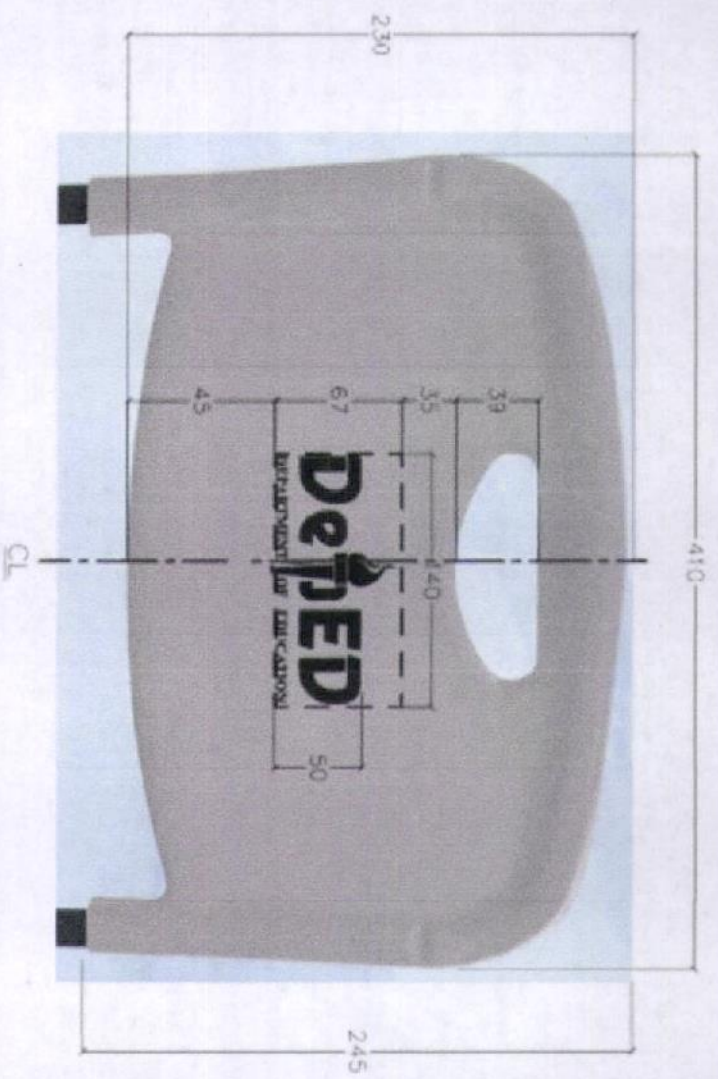

- SPECIFICATIONS:**
1. MATERIAL: BLOW MOLDED HDPE.
  2. MARKINGS: MINIMUM OF 0.8MM DEPTH EMBOSSED / MOLDED OFFICIAL "DEPED LOGO" WITH THE INSCRIPTION "DEPARTMENT OF EDUCATION" AS PER DRAWING.
  3. COLOR CODE: PANTONE 4665C OR COLOR HEX: #cda788 / RGB: 205, 167, 136 / CMYK: 0%, 19%, 34%, 20%
  4. DEPED LOGO COLOR IS THE SAME AS BACKREST COLOR CODE.
- NOTE: BLACK COLOR OF LOGO SHOWN IS FOR ILLUSTRATION ONLY.

<p>DEPARTMENT OF EDUCATION BUREAU OF ASSISTANT SECRETARIES BUREAU OF TECHNICAL EDUCATION</p>	<p>DESIGNER: <i>[Signature]</i> ARCHITECT</p>	<p>RECOMMENDING APPROVAL: <i>[Signature]</i> ENGR. AMBERLENE PANAN CHIEF - EDUCATION FACILITIES DIVISION</p>	<p>APPROVED BY: ALAN DEL B. PASOJA UNDERSECRETARY FOR ADMINISTRATION</p>	<p>PROJECT TITLE: LEARNER &amp; TEACHER'S CHAIR - HDPE BACK DEPED LOGO DETAIL (HDPE &amp; STEEL)</p>	<p>SHEET CONTENTS: HDPE BACK DEPED LOGO DETAIL PERSPECTIVE VIEW SPECIFICATIONS</p>	<p>SHEET NO: 1</p>
--	---	--	--	--	--	--------------------

# DEPED SECONDARY LEARNER'S CHAIR

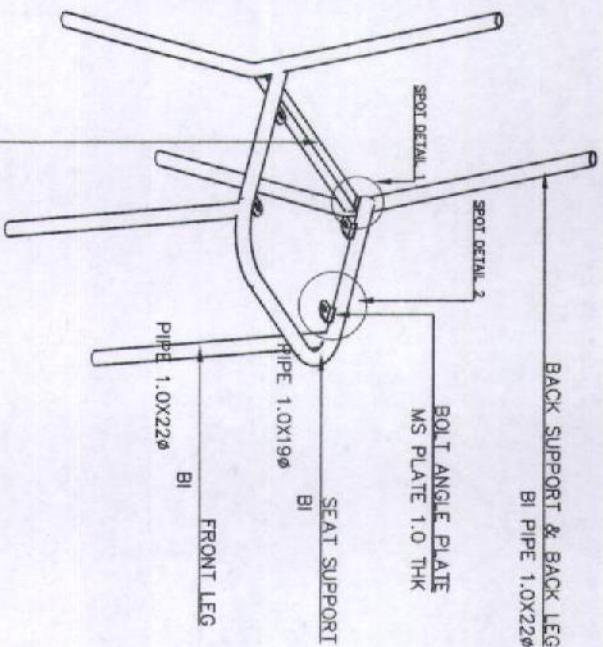
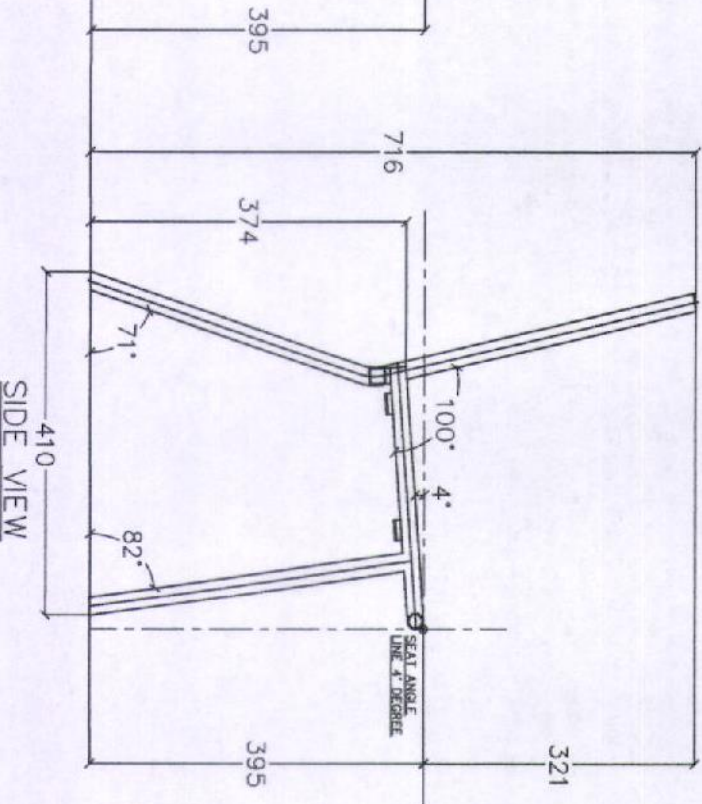
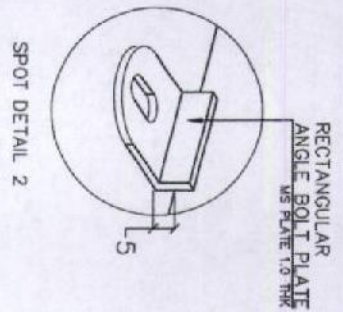
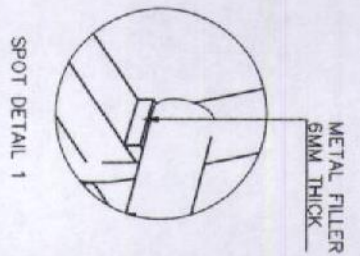
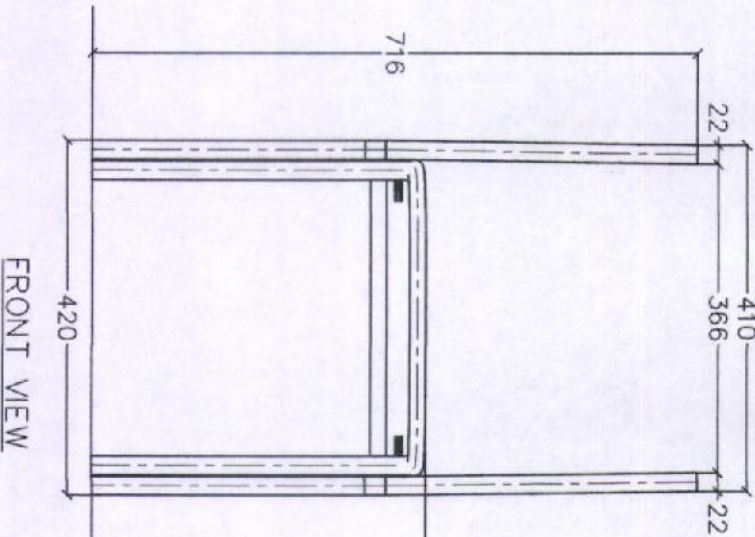
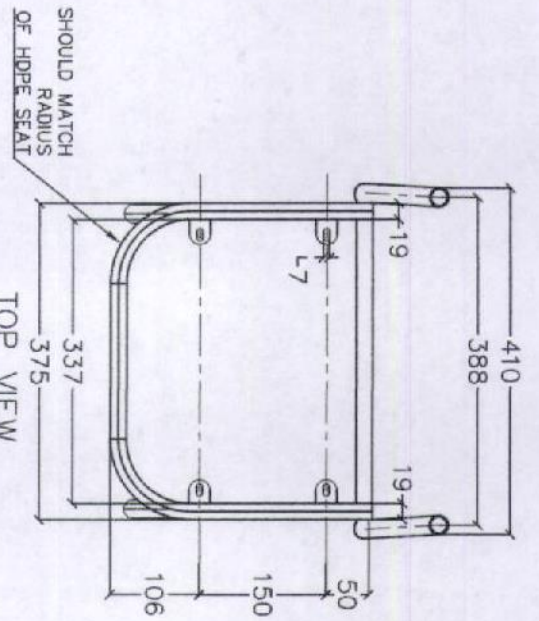

PERSPECTIVE VIEW

<p>DEPED DEPARTMENT OF EDUCATION BUREAU OF ELEMENTARY EDUCATION BUREAU OF SECONDARY EDUCATION</p>	<p>DESIGNER: <i>LET ROBERTO G. MANSO</i> ARCHITECT</p>	<p>RECOMMENDING APPROVAL: <i>ENGR. ANTONIO R. JANSAN</i> CHIEF - EDUCATION FACILITIES DIVISION</p>	<p>APPROVED BY: <i>ALAN DEL B. PASCUA</i> UNDERSECRETARY FOR ADMINISTRATION</p>	<p>PROJECT TITLE: <b>LEARNER'S CHAIR (HDPE &amp; STEEL)</b></p>	<p>SHEET CONTAINS: SECONDARY LEARNER'S CHAIR -PERSPECTIVE VIEW -DETAILS</p>	<p>SHEET NO. 5</p>
	<p>REVISION NO.:</p>	<p>REVISIONS:</p>	<p>DATE:</p>	<p>SCALE:</p>	<p>PROJECT NO.:</p>	<p>DATE:</p>

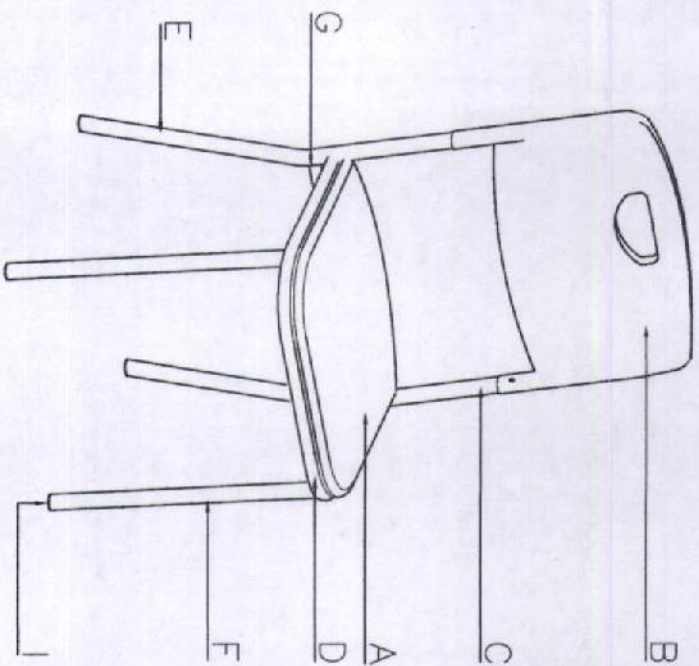

1 ISOMETRIC VIEW OF LEARNER'S CHAIR  
SCALE 1:1

DIMENSIONS OF LEARNER'S CHAIR (mm)

COMPONENTS	DIMENSIONS	
	ELEMENTARY	SECONDARY
SEAT HEIGHT	392	412
SEAT DEPTH	380	380
SEAT WIDTH	370	370
BACK HEIGHT	775	800
BACK WIDTH	410	410

TECHNICAL SPECIFICATIONS OF LEARNER'S CHAIR

MARK	COMPONENTS	SPECIFICATIONS
1	SEAT	BLOW MOLDED PLASTIC HIGH-DENSITY POLYETHYLENE (HDPE)
A	SEAT	BLOW MOLDED PLASTIC HIGH-DENSITY POLYETHYLENE (HDPE)
B	BACK	BLOW MOLDED PLASTIC HIGH-DENSITY POLYETHYLENE (HDPE)
B	BACK SUPPORT	BLOW MOLDED PLASTIC HIGH-DENSITY POLYETHYLENE (HDPE)
C	BACK SUPPORT	BI PIPE TUBE 1.0MMX22MMØ
D	SEAT SUPPORT	BI PIPE TUBE 1.0MMX19MMØ
E	BACK LEG	BI PIPE TUBE 1.0MMX22MMØ
F	FRONT LEG	BI PIPE TUBE 1.0MMX22MMØ
G	LOWER SEAT SUPPORT	SQ. TUBE 1.0MMX19MMX19MM
I	COVER CAP	PLASTIC GLIDE
	HDPE TO STEEL:	BACK HDPE TO STEEL - SELF TAPPING SCREW
		SEAT HDPE TO STEEL - 1MM THK 25MMX30MM FLAT BAR, M6X12 BOLT

SCHEDULE OF FINISHES

BLOW MOLDED	HIGH-DENSITY POLYETHYLENE (HDPE) PLASTIC
METAL/STEEL TUBULAR	60-80 MICRON POWDER COAT FINISH FLAT BLACK FINISH
HDPE COLOR	REFER TO COLOR CODE PANTONE 4665C OR COLOR HEX: #cda788 / RGB:205, 167, 136 / CMYK: 0% 19% 34% 20%

**DepEd** DIVISION OFFICE - MARIKINA CITY  
 REGIONAL EDUCATION SUPERVISOR  
 HEDRAZON J. DELIBERTOS  
 HIKILAN AVENUE, MARIKINA CITY

DESIGNED BY: JET RIVERA S. RUBISO ARCHITECT  
 RECOMMENDING APPROVAL: ENGR. MARICELITA MANOG CHIEF - EDUCATION FACILITIES DIVISION  
 APPROVED BY: ALAN DEL B. PASCUA UNDERSECRETARY FOR ADMINISTRATION

PROJECT TITLE: **LEARNER'S CHAIR (HDPE & STEEL)**  
 SHEET NO. 1 / 5  
 SHEET DIMENSIONS: TECHNICAL SPECIFICATION SCHEDULE OF FINISHES SCHEDULING APPLICATION ISOMETRIC VIEW  
 CY 2021